

DOP-B03

B03S211 / B03E211 Instruction Sheet

(1) Preface

Thank you for purchasing DELTA's DOP-B series. This instruction sheet will be helpful in the installation, wiring and inspection of Delta HMI. Before using the product, please read this instruction sheet to ensure correct use. You should thoroughly understand all safety precautions before proceeding with the installation, wiring and operation. Place this instruction sheet in a safe location for future reference. Please observe the following precautions:

- Install the product in a clean and dry location free from corrosive and inflammable gases or liquids.
- Ensure that all wiring instructions and recommendations are followed.
- Ensure that HMI is correctly connected to a ground. The grounding method must comply with the electrical standard of the country (Please refer to NFPA 70: National Electrical Code, 2005 Ed.).
- Do not disassemble HMI, modify or remove wiring when power is applied to HMI.
- Do not touch the power supply during operation. Otherwise, it may cause electric shock.

(2) Safety Precautions

Carefully note and observe the following safety precautions when receiving, inspecting, installing, operating, maintaining and troubleshooting. The following words, DANGER, WARNING and STOP are used to mark safety precautions when using the Delta's HMI product. Failure to observe these precautions may void the warranty!

Installation



- Comply with quick start for installation. Otherwise it may cause equipment damage.
- Do not install the product in a location that is outside the stated specification for the HMI. Failure to observe this caution may result in electric shock, fire, or explosion.
- Do not install the product in a location where temperatures will exceed specification for the HMI. Failure to observe this caution may result in abnormal operation or damage the product.
- Please note that this equipment has obtained EMC registration for commercial use. In the event that it has been mistakenly sold or purchased, please exchange it for equipment certified for home use.
- Do not use this product as an alarm device for disaster early warning that may result in personal injury, equipment damage, or system emergency stop.

Wiring



- Connect the ground terminals to a class-3 ground (Ground resistance should not exceed 100Ω). Improper grounding may result in communication error, electric shock or fire.

Operation



- The users should use Delta Screen Editor software to perform editing in Delta's HMI product. To perform editing and confirming HMI programs without using Delta Screen Editor software in Delta's HMI product may result in abnormal operation.
- To prevent the personal injury and equipment damage, when designing HMI programs, please ensure that a communication error occurred between Delta's HMI product and the connecting controller or equipment will not result in system failure or malfunction.
- Please be sure to backup the screen data and HMI programs in case they are lost, accidentally deleted or worse.



- Do not modify wiring during operation. Otherwise it may result in electric shock or personal injury.
- Never use a hard or pointed object to hit or strike the screen as doing this may damage the screen and let the screen has not respond at all, and then cause HMI to work abnormally.

Maintenance and Inspection



- Do not touch any internal or exposed parts of the HMI as electrical shock may result.
- Do not remove operation panel while power is on. Otherwise electrical shock may result.
- Wait at least 10 minutes after power has been removed before touching any HMI terminals or performing any wiring and/or inspection as an electrical charge may still remain in the HMI with hazardous voltages even after power has been removed.
- Turn the power off before changing backup battery and check system settings after finishing change. (all data will be cleared after changing battery).
- Be sure the ventilation holes are not obstructed during operation. Otherwise malfunction may result due to bad ventilation or overheating troubles.

Wiring Method



- Do not use a voltage that will exceed specification for the HMI. Failure to observe this caution may result in electric shock or fire.
- Remove the terminal block from the HMI before wiring.
- Insert only one wire into one terminal on the terminal block.
- If the wiring is in error, perform the wiring again with proper tools. Never use force to remove the terminals or wires. Otherwise, it may result in malfunction or damage.
- For the power line that forced to take out, ensure to check wiring again and restart.

Communication Wiring



- Comply with communication wiring specification for wiring.
- Wiring length should comply with the stated specification for the HMI.
- Proper grounding to avoid bad communication quality.
- To avoid noise and interference, the communication cable, all power cables, and motor power cable should be placed in separate conduits.

(3) Pin Definition of Serial Communication

DOP-B03S211 / DOP-B03E211 COM1 and COM2 Ports

COM Port	PIN	MODE1		MODE2		MODE3	
		COM1	COM2	COM1	COM2	COM1	COM2
	1	RS-232	RS-485	RS-485	RS-485	RS-232	RS-422
	2	RXD		D+		RXD	TXD+
	3	TXD				TXD	
	4		D+		D+		RXD+
	5	GND		GND		GND	
	6			D-			TXD-
	7	RTS					
	8	CTS					
	9		D-		D-		RXD-

Note1: Blank = No Connection.

(4) Parts Names

DOP-B03S211 / DOP-B03E211 (Front View)

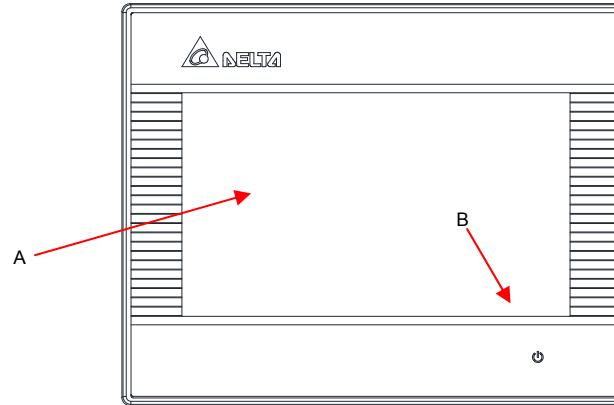

A	Touch Screen / Display	
B	Power LED Indicator ()	Note: () Lights in green when HMI works normally.

DOP-B03S211 (Rear View)

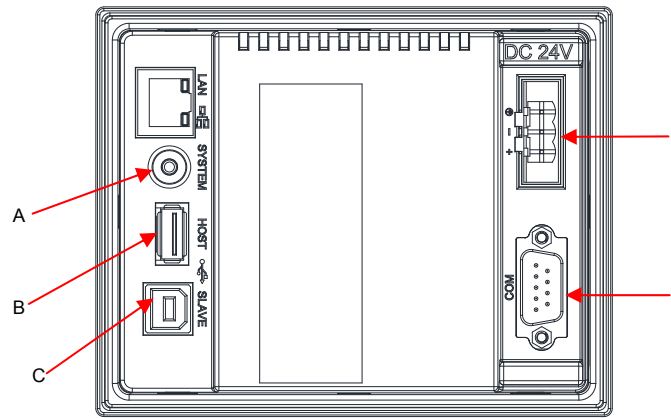

A	System Key	B	USB Host	C	USB Slave
D	Power Input Terminal	E	COM1		

DOP-B03E211 (Rear View)

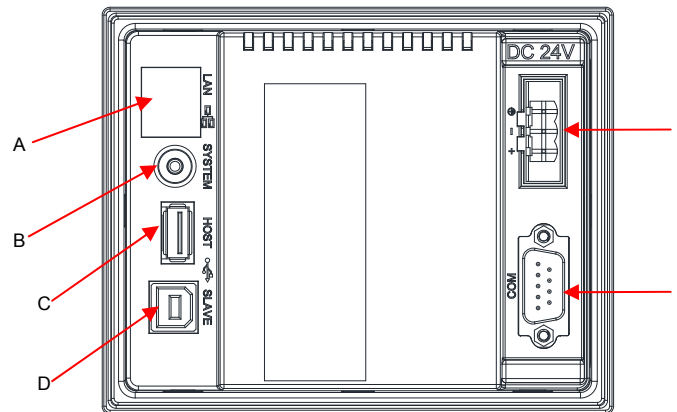

A	Ethernet Interface (LAN)	B	System Key	C	USB Host
D	USB Slave	E	Power Input Terminal	F	COM 1

(5) Dimensions

DOP-B03S211 / DOP-B03E211

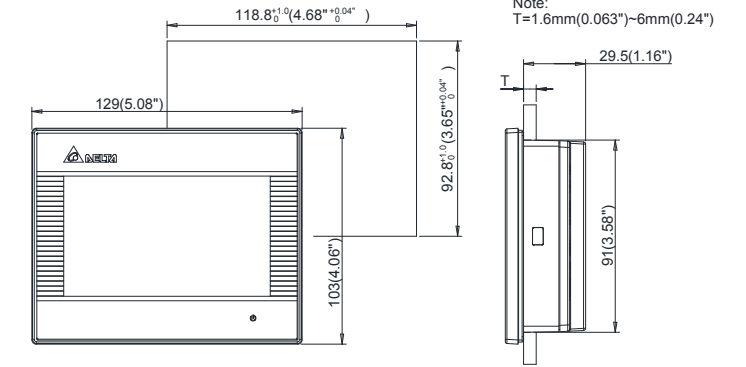

(6) Specifications

MODEL		DOP-B03S211	DOP-B03E211
LCD MODULE	Display Type	4.3" TFT LCD (65536 colors)	
	Resolution	480 x 272 pixels	
	Backlight	LED Back Light (less than 20,000 hours half-life at 25°C) (Note 1)	
	Display Size	95.04 x 53.856mm	
Operation System		Delta Real Time OS	
MCU		32-bit RISC Micro-controller	
NOR Flash ROM		Flash ROM 128 MB (OS System: 30MB / Backup: 16MB / User Application: 82MB)	
SDRAM		64Mbytes	
Backup Memory		32Kbytes	
Buzzer		Multi-Tone Frequency (2K ~ 4K Hz) / 85dB	
USB		1 USB Slave Ver 2.0 1 USB Host Ver 1.1	
Serial COM Port	COM1	RS-232(supports hardware flow control) / RS-485	
	COM2	RS-422/RS-485	
Ethernet Interface		N/A	10M/100M
Perpetual Calendar		Built-in	
Cooling Method		Natural air circulation	
Safety Approval		CE / UL (Note 3)	
Waterproof Degree		IP65 / NEMA4 (Note 3)	
Operation Voltage (Note2)		DC +24V (-10% ~ +15%) (please use isolated power supply)	
Voltage Endurance		AC500V for 1 minute (between charging (DC24V terminal) and FG terminals)	
Power Consumption (Note 2)		4.8W	7.2W
Backup Battery		3V lithium battery CR2032 x 1	
Backup Battery Life		It depends on the temperature used and the conditions of usage, about 3 years or more at 25°C.	
Operation Temperature		0°C ~ 50°C	
Storage Temperature		-20°C ~ +60°C	
Ambient Humidity		10% ~ 90% RH [0 ~ 40°C], 10% ~ 55% RH [41 ~ 50°C], Pollution Degree 2	
Vibration		IEC 61131-2 compliant 5Hz≤f<8.3Hz = Continuous: 3.5mm, 8.3Hz≤f≤150Hz = Continuous: 1.0g	
Shock		IEC 60068-2-27 compliant 15g peak for 11 ms duration, X, Y, Z directions for 6 times	
Dimensions (W) x (H) x (D) mm		129 x 103 x 39	
Panel Cutout (W) x (H) mm		118.8 x 92.8	
Weight		Approx. 230g	Approx. 264g